

94020 Conservation Vent (Pressure & Vacuum)

The Shand & Jurs Model 94020 Conservation Vent is designed utilizing over 90 years of experience in producing high quality and dependable conservation fittings. Continued design improvements provide these vents with high efficiency, maximum flow capacity and minimum leakage. The easily serviceable configuration and lightweight construction reduces maintenance and installation costs.

Standard materials of construction are low copper aluminum, cast iron, ductile iron, cast steel and 316 stainless steel for body materials. Aluminum, stainless steel and steel body vents come standard with integral seats and have optional replaceable seats. Cast iron and ductile iron bodies come with replaceable seats as standard design. Replaceable seats are made of corrosion resistant molded thermosetting phenolic, Teflon, aluminum, 316 stainless steel or stainless steel Teflon coated and are easily replaced.

Diaphragms are air cushion seated and are constructed of FEP Teflon for reliability and extended service life. Teflon diaphragms contribute to high resistance to adhesion of ice and gum formations, thus assuring protection against pallet sticking to the seating surface. The body is self-draining and drip rings keep condensates from the seating surfaces. The carefully engineered body, seat, and pallet assembly results in a superior combination of tight sealing and high capacity at low over-pressure with minimal blow down.

Conservation Vents are available in a full range of sizes and configurations, such as closed vent hoods (pipe-away), cryogenic hoods and flame snuffers. Standard pressure and vacuum settings are 1/2 oz./sq. in. The 94020 Conservation Vent is available with optional pressure and vacuum limit switches and visual indicators.

Expanda-Seal

Shand & Jurs "Expanda-Seal" option is available on all pressure pallet assemblies. This feature significantly reduces leakage. The ballooning effect of the Teflon diaphragm effectively seals the valve.

The "Expanda-Seal" feature ensures less than .5 SCFH of air at 95% of the set point.

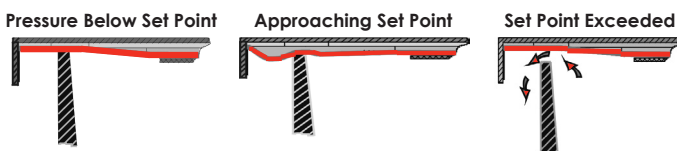

Open Vent



Closed Vent

Features

- Suitable materials available for corrosive/extreme temperature service pallet reaction lip for smooth lift and reseating
- Pallet reaction lip for smooth lift and reseating
- Vertical lift pallets assure reliable operation and maximum flow
- Floating diaphragm results in a positive seal and minimal blow-down
- "All weather" coating, insulation jackets and steam jacketing options available
- Capacity certified to API Standards

Conservation Vent Specifications:

Sizes:

2", 3", 4", 6", 8", 10" & 12"

Settings*:

Standard Pressure & Vacuum: 1/2 oz./in.² (.865 in. W.C.)

Expanda-Seal Pressure Setting:

1.5 oz./in.² Minimum (Consult Factory for lower settings)

Maximum Setting W/O Modification:

	(Pressure)	(Vacuum)**
2":	18 oz./in. ²	8 oz./in. ²
3":	18 oz./in. ²	9 oz./in. ²
4":	18 oz./in. ²	11 oz./in. ²
6":	12 oz./in. ²	12 oz./in. ²
8":	10 oz./in. ²	14 oz./in. ²
10":	8 oz./in. ²	17 oz./in. ²
12":	6 oz./in. ²	21 oz./in. ²

Service and Body Material:

Normal: Cast Low Copper Aluminum
 Low Temperature: Cast Low Copper Aluminum
 Severe: Cast Iron, Ductile Iron, Cast Steel, Cast 316 Stainless Steel
 Integral Seats: Same as body; Aluminum, 316 SS, Cast Steel with 316 Stainless Steel seat overlay

Temperature Range:

Body and Seal -40°F to 220°F. Options for Process Temperature Ranges of -300°F to 500°F

Replaceable Seats:

Ryton for: 2" size
 Phenolic for: 3" Thru 12" sizes
 Aluminum for: 2", 3", 4", 6", 8", 10" & 12" sizes
 316 Stainless Steel for: 2", 3", 4", 6", 8", 10" & 12" sizes
 Teflon for: 2", 3", 4", 6", 8" sizes
 SS Teflon Coated for: 2", 3", 4", 6", 8", 10" & 12" sizes

Type of Flange Connection:

Screwed or flanged for: 2" & 3" sizes
 Flanged for: 4", 6", 8", 10" & 12" sizes
 Raised face flange available, except for aluminum body material.

Options Available:

Flame Snuffer for all sizes (open vent) and material, except low temperature service. Closed vent for all sizes and materials. Material substitutions as required. Cleaning for LOX/LIN service.

NOTES:

** Modifications may be required to vacuum port for installations where product contamination may occur. See figure 4 for Principle of Operation. Caution— any obstruction to vacuum port may alter the set point.

Standard Materials of Construction

Component	Normal Aluminum	Low Temperature	Severe		
Body	Cast Aluminum	Cast Aluminum	Cast Iron/Ductile Iron	Cast Steel	316 Stainless Steel
Cover	Aluminum	Aluminum	Steel	Steel	316 Stainless Steel
Hood	18-8 Stainless Steel, PA ¹	Aluminum ²	18-8 Stainless Steel, PA ¹	18-8 Stainless Steel, PA ¹	316 Stainless Steel
Seats ³	Aluminum	Aluminum	316 Stainless Steel	C.S. with 316 SS Overlay	316 Stainless Steel
Stem Guide	Galvanized Iron	316 Stainless Steel	Galvanized Iron	Galvanized Iron	316 Stainless Steel
Pallets	Aluminum	Aluminum	316 Stainless Steel	316 Stainless Steel	316 Stainless Steel
Pressure Stem	316 Stainless Steel	316 Stainless Steel	316 Stainless Steel	316 Stainless Steel	316 Stainless Steel
Vacuum Stem	Aluminum ⁴	Aluminum ⁴	316 Stainless Steel	316 Stainless Steel	316 Stainless Steel
Screens	Galvanized Steel	304 Stainless Steel	304 Stainless Steel	304 Stainless Steel	316 Stainless Steel
Retainer	Aluminum	Aluminum	316 Stainless Steel	316 Stainless Steel	316 Stainless Steel
Hardware	Zinc Plated Steel	316 Stainless Steel	316 Stainless Steel	Zinc Plated Steel	316 Stainless Steel
Diaphragms	FEP Teflon	FEP Teflon	FEP Teflon	FEP Teflon	FEP Teflon

NOTES: 1. 18-8SS for 2", 3", 4", 6" & 8" sizes; spun alum. for 10" & 12" sizes.
 2. 2", 3", 4", 6", 8", 10" & 12" sizes; alum. enclosure w/flapper.

3. Material same as body except CI and DI.
 4. 316SS for elevated settings.

PA - Spun Aluminum CS - Cast Steel

Principle of Operation

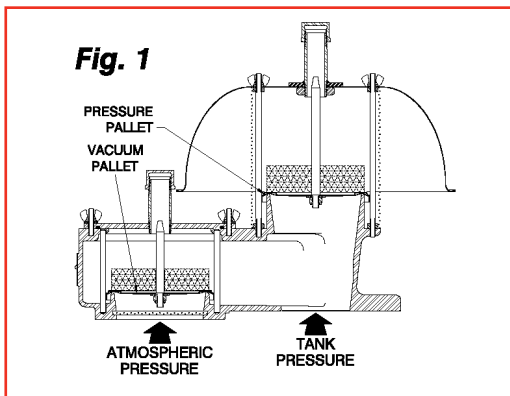

Figures 1 and 3 show the relation of the pressure or vacuum pallet assembly to the seat when atmospheric and tank pressures are equal. The "wrap around" effect of the resilient diaphragm on the edge of the seat and the resulting high ratio of seating force to seating area affords a tight seal.

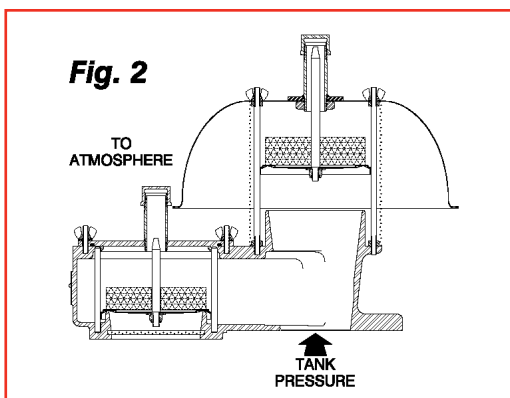

As the pressure or vacuum increases, the pallet begins to rise. Because there is still a wrap-around effect on the edge of the seat, good sealing is maintained. Teflon diaphragm memory and lapped seating surface further enhance sealing characteristics.

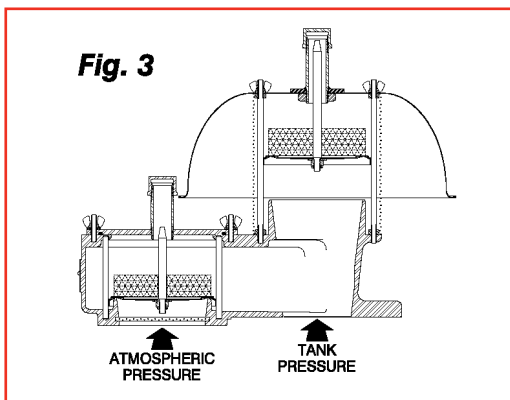

As increasing pressure or vacuum continues to lift the pallet, the diaphragm is held in close proximity to the seat by the flat plane memory of the diaphragm material.

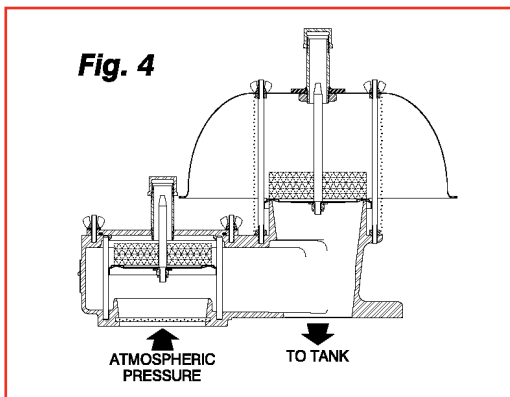

As set pressure or vacuum is reached the diaphragm leaves the seat (see Figures 2 and 4) and the escaping vapor lifts the pallet even further.

The vacuum pallet is guided in the same manner as the pressure pallet. Both are pallet stem and pallet side guided for smooth movement.

Steam Jacket Option:

Designed for use on tanks containing liquids whose vapors crystallize at ambient temperatures. Stainless steel pressure and vacuum pallets are cased in a steam heated jacket ensuring the valves will be free from plugging. The jacket is steel or stainless steel construction. The standard jacket can withstand steam pressures up to 100 psig. Higher pressure ratings are available.

6", 8", 10" & 12" Cryogenic Hood Model

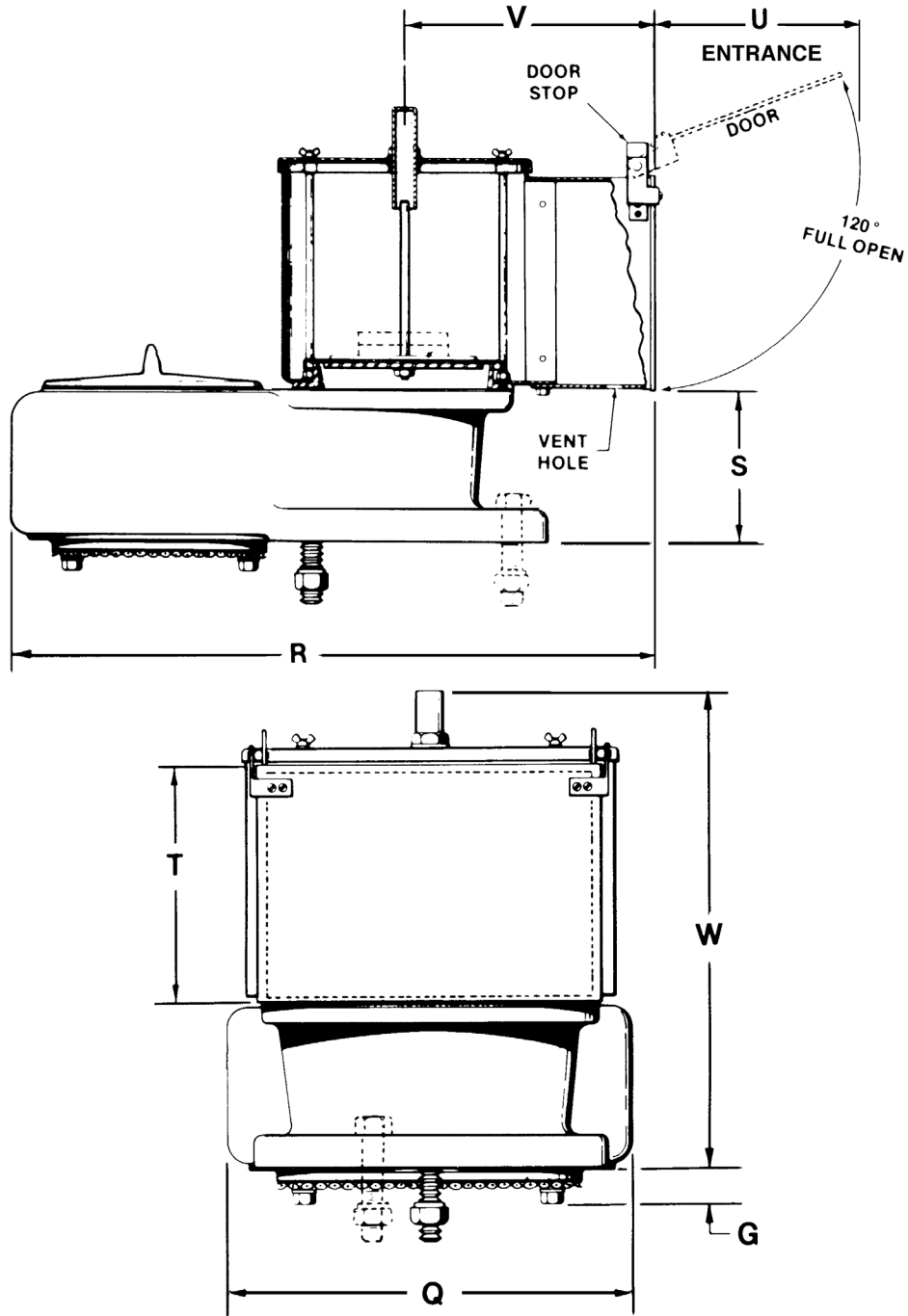

Vent Size* (In.)	Dimensions in Inches						
	R	Q	S	T	U	V	W
6	30	12 1/8	5 5/8	8 1/8	8 1/2	11 1/2	17 1/16
8	34 1/2	14 1/16	7 3/8	9 5/8	10	12 1/2	21 1/4
10	41	17 1/2	8 3/8	11 3/8	11 5/8	14 3/16	25 1/2
12	44 1/2	19 3/4	10	12 5/8	13	15 3/8	29 7/8

94020 Conservation Vent (Pressure & Vacuum)



94020 Closed Vent

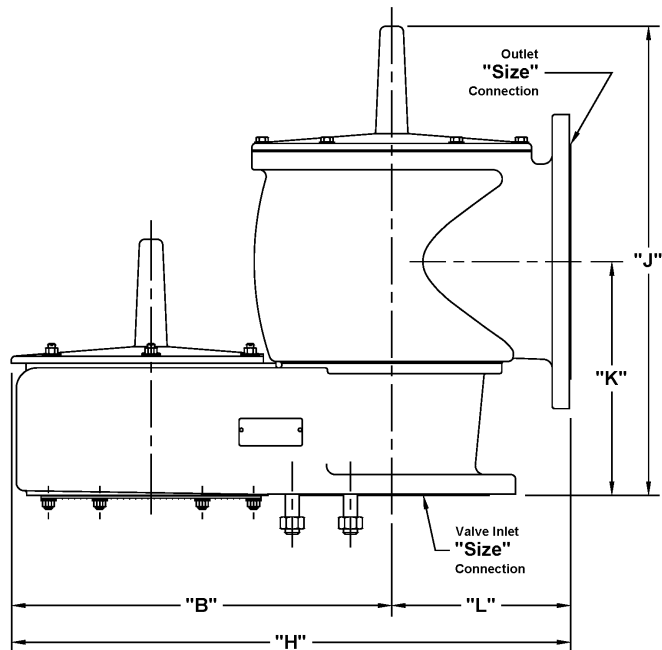

Valve Size	Outlet Size	"H"	"J"	"K"	"L"	"B"
2"	2"	13	11 1/8	5 1/32	4 1/4	8 3/4
2"	3"	13	11 1/8	5 1/32	4 1/4	8 3/4
* 3"	3"	16 3/8	13 1/4	5 9/16	5 1/4	11 1/8
3"	4"	16 3/16	13 3/4	5 31/32	5 1/4	10 15/16
* 4"	4"	20	20 3/8	7	6 1/2	13 1/2
4"	6"	19 1/4	15 3/4	7 1/32	5 15/16	13 5/16
* 6"	6"	26 1/4	21 1/4	9 3/8	8 3/8	17 7/8
6"	8"	26 3/16	21 1/4	10 11/32	8 1/4	17 15/16
* 8"	8"	31 5/8	25 1/2	11 11/16	9 3/4	21 7/8
8"	10"	31 5/8	26 3/16	12 23/32	9 3/4	21 7/8
* 10"	10"	37 7/8	30	13 7/8	11 19/32	26 3/32
10"	12"	37 7/8	30 1/4	14 29/32	11 19/32	26 3/32
* 12"	12"	43 3/8	33 7/8	16 1/4	12 13/16	30 9/16
12"	14"	43 3/8	33 7/8	16 29/32	12 13/16	30 9/16

*Table D option 5 for same size inlet and outlet connections has been obsoleted and replaced by Table D option 6. Dimensions do not match. Consult Factory for replacement valve.

NOTES:

1. Connection size matches ANSI, DIN & JIS.
2. Mounting Holes straddle centerline except: 2" & 3" sizes; holes are on centerline.
3. Optional NPT Adapter available for 2" & 3".

94020 Open Vent

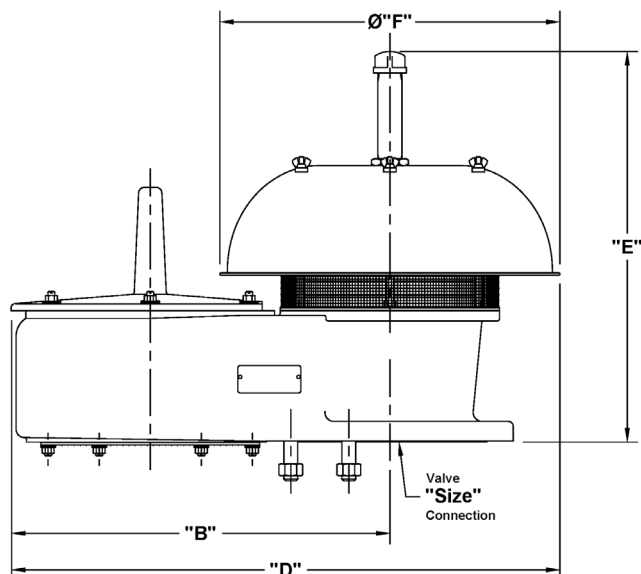

Valve Size	"B"	"D"	"E"	Diameter "F"
2"	9	15 1/4	11 1/8	12 7/8
3"	11 1/8	17 15/16	13 3/4	13 9/16
4"	13 1/2	21 1/2	15 3/4	15 15/16
6"	17 15/16	28 1/2	18 3/4	18 5/8
8"	21 7/8	31 3/16	21 1/4	18 5/8
10"	26 1/4	40 5/8	28 1/8	25 9/16
12"	30 9/16	44 5/8	32 1/4	29 7/8

NOTES:

1. Connection size matches ANSI, DIN & JIS.
2. Mounting Holes straddle centerline except: 2" & 3" sizes; holes are on centerline.
3. Optional NPT Adapter available for 2" & 3".

All designs subject to change. Certified dimensions and specifications available upon request



94020 Ordering Guide

Conservation Vents provide tank venting and breathing with high efficiency, maximum flow capacity and minimum leakage. Standard materials of construction include low copper aluminum, cast iron, ductile iron, cast steel, and 316 Stainless Steel. The 94020 comes in open or closed vent versions, and in sizes 2" through 12". Cryogenic hoods, flame snuffers, limit switches and steam jacketing and steam tracing are available.

Benefits

- Low copper aluminum alloy construction reduces need for special materials in corrosive and extreme temperature service
- Capacity certified in accordance with API standards
- Expanda-Seal diaphragm for reduced leakage
- Unique floating diaphragm construction assures positive seal and minimal blowdown, thus conserving valuable tank content
- Peripheral and stem guided pressure pallet assures smooth lift and closure

Model Number Selection

The model number will have a base number 94020 followed by 8 digit numbers. These digits will represent 7 sets of option tables.

94020 - AB - CD - EF - GH

*NOTE: If ATEX (A) Unit is required, please use 94020A AB CD EF GH.

If CE (C) Unit is required, please use 94020C AB CD EF GH.

Ordering Information

Specify:

1. Model 94020 Conservation Vent
2. Size and Body Material
3. Screwed or Flanged Connection on 2" and 3" Size
4. Closed Vent or Vent to Atmosphere (With or without flame snuffer)
5. Pressure and Vacuum Settings (if other than normal setting)
6. Type of Cleaning (if for oxygen service)
7. Optional Materials of Construction, as Required
8. To Specify CE for Ordinary EU Locations use 94020C AB CD EF GH
9. To Specify ATEX Certification for Group IIB, IIA EU Locations use 94020A AB CD EF GH. ATEX Certification includes CE Mark.

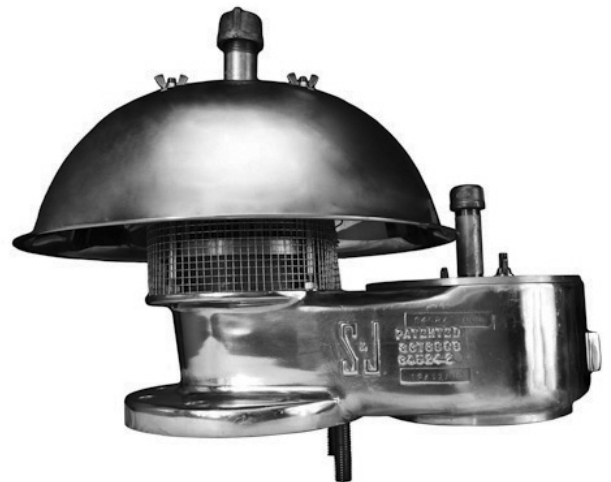

Table AB - Size and Body Material

Option AB	Size	Type of Connection	Body Material
11	2"	NPT	Aluminum
12	2"	Flanged	Aluminum
21	2"	NPT	Alum. Cryo Hood
22	2"	Flanged	Alum. Cryo Hood
*31/41	2"	NPT	Cast Iron/Ductile Iron
*32/42	2"	Flanged	Cast Iron/Ductile Iron
51	2"	NPT	Cast Steel
52	2"	Flanged	Cast Steel
71	2"	NPT	316 Stainless Steel
72	2"	Flanged	316 Stainless Steel
13	3"	NPT	Aluminum
14	3"	Flanged	Aluminum
23	3"	NPT	Alum. Cryo Hood
24	3"	Flanged	Alum. Cryo Hood
*33/43	3"	NPT	Cast Iron/Ductile Iron
*34/44	3"	Flanged	Cast Iron/Ductile Iron
53	3"	NPT	Cast Steel
54	3"	Flanged	Cast Steel
73	3"	NPT	316 Stainless Steel
74	3"	Flanged	316 Stainless Steel
15	4"	Flanged	Aluminum
25	4"	Flanged	Alum. Cryo Hood

*3X = Cast Iron 4X = Ductile Iron
 **For NPT Connections, Specify Table C0

Option AB	Size	Type of Connection	Body Material
*35/45	4"	Flanged	Cast Iron/Ductile Iron
55	4"	Flanged	Cast Steel
75	4"	Flanged	316 Stainless Steel
16	6"	Flanged	Aluminum
26	6"	Flanged	Alum. Cryo Hood
*36/46	6"	Flanged	Cast Iron/Ductile Iron
56	6"	Flanged	Cast Steel
76	6"	Flanged	316 Stainless Steel
17	8"	Flanged	Aluminum
27	8"	Flanged	Alum. Cryo Hood
*37/47	8"	Flanged	Cast Iron/Ductile Iron
57	8"	Flanged	Cast Steel
77	8"	Flanged	316 Stainless Steel
18	10"	Flanged	Aluminum
28	10"	Flanged	Alum. Cryo Hood
*38/48	10"	Flanged	Cast Iron/Ductile Iron
58	10"	Flanged	Cast Steel
78	10"	Flanged	316 Stainless Steel
19	12"	Flanged	Aluminum
29	12"	Flanged	Alum. Cryo Hood
*39/49	12"	Flanged	Cast Iron/Ductile Iron
59	12"	Flanged	Cast Steel
79	12"	Flanged	316 Stainless Steel

Table C - Flange Type

Option C	Description
0	FF ANSI 150 lb
1	*RF ANSI 150 lb
2	DIN PN 16 FF
3	DIN PN 16 RF*
4	JIS 10K FF
5	JIS 10K RF*

* RF not available in Aluminum

Table D - Vent Type

Option D	Description
1	Open Vent
2	Open Vent w/ Flame Snuffer
3	Closed, Standard Outlet > Inlet*
4	Pipe Away, P&V
6	Pipe Away, Same Size Inlet, Outlet, Seat
7	Open Vent with "All Weather" Coating
8	Open Vent with Flame Snuffer with "All Weather" Coating
9	Closed, Standard Outlet > Inlet with "All Weather" Coating
A	Pipe Away, Same Size Inlet, Outlet, Seat with "All Weather Coating

* Standard closed vent (outelet is one size larger than the inlet).
 Ex. 2" Inlet X 3" Outlet, 6" Inlet X 8" Outlet.

NOTE: Replaced Option 5. Dimensions are not idetnical. Consult Factory if replacement valve is required.

Table E - Seal Type and Softgoods

Option E	Description
0	Normal FEP / N8090
1	Expanda-Seal FEP / N8090
2	Normal FEP (All)
3	Expanda-Seal FEP (All)
4	Normal Viton
5	Expanda-Seal Viton
6	Normal PTFE
8	Normal Buna
9	Expanda-Seal Buna

Table F - Pressure Range & Load Weight Material

Option F	Description	Material
1	**Standard Pressure and Vacuum Setting = 0.5 oz./sq. in	Lead
2	Over 2.9 oz./sq. in. to Maximum Setting	Lead
3	> Standard to 2.9 oz./sq. in.	Lead
4	**Standard Setting	316 SS
5	Over 2.9 oz./sq. in. to Maximum Setting	316 SS
6	> Standard to 2.9 oz./sq. in.	316 SS
7	Incremental Weights Pressure Only 2.9 Oz. - 14 Oz. (5 in. W.C. - 24 in. W.C.)	Lead
8	Standard Incremental Weight Set Pressure Only 6" -16" W.C. in 1" Increments Including (1)-1/2 In. and (2)-1/4 In. W.C. Weights	Lead

**Expanda-Seal min. pressure setting: 1.5 oz./sq. in.

Table G - Seat & Pallet Material

Option G	Seat	Pallet
0	Standard*	Standard*
+1	Teflon	Standard*
2	Aluminum	Standard*
+3	Phenolic	Standard*
4	Stainless Steel	Standard*
5	Teflon Coated SS	Standard*
A	Standard*	316 Stainless Steel
+B	Teflon	316 Stainless Steel
C	Aluminum	316 Stainless Steel
+D	Phenolic	316 Stainless Steel
E	Stainless Steel	316 Stainless Steel
F	Teflon Coated SS	316 Stainless Steel

*See Materials of Construction

+ These Options not Available with ATEX Models

Options A-F are applicable for Aluminum bodies only. 316 SS Pallet is standard on all other body options.

Table H - LOX (Liquid Oxygen) & LIN (Liquid Nitrogen) Cleaning, Trim

Option H	Cleaning	Trim
0	Normal	Standard
1	LOX	Standard
2	LIN	Standard
5	Normal	316 Stainless Steel
6	LOX	316 Stainless Steel
7	LIN	316 Stainless Steel
8	Normal	Monel
9	LOX	Monel
A	LIN	Monel

For an ATEX Certified Valve choose Option 5, 6, 7. Trim includes Stem, Stem Guides, Side Guides, Nuts, Bolts, and Screen.

NOTE: LOX/LIN cleaning for Cryogenic Breathers of aluminum construction includes degreasing before assembly only!